

Compact Tri-sector Quad-band (BB/BB/BB/BB)D450 antenna for BTS



Features

Frequency bands

- 1710-2170 MHz
- 1710-2170 MHz.
- 1710-2170 MHz.
- 1710-2170 MHz.

Multisector configuration

Monosector, bisector 120°, bisector 180° and trisector configuration available.

Variable Electrical Tilt, RET

- Wide Electrical Tilt range (4-14°).
- Ready for RET configuration.

Double azimuth

Global azimuth (+/-50°) and independent azimuth for each sector (+/-5°).

Accessibility

The lower compartment allows easy access to connectors and antenna adjusting (azimuth and tilt).

Minimum size

Minimum weight and size in the market, thanks to fractal technology. It reduces stress due to wind and structural requirements.

MAST + ANTENNA SOLUTION

Minimum visual impact

Its small size, together with the mast and add-ons integrated into city scapes, reduces visual impact to the minimum, making it easier to find installation sites.

Increased safety

The safety systems included reduce the risk of accidents and the need to work at height. Availability of access for installers only.

Cost savings

Folding Mast: Reduces installation time and costs, without expensive work at height. Modular Mast and Base Plate: no crane or civil work costs, resulting in high productivity. It makes it possible to work under adverse weather conditions. Cables channelled inside the mast.

Description

The TELNET **Compact Tri-sector Quad-band (BB/BB/BB/BB)D450 antenna** is part of the **ENVIA** family, a new generation of antennas for mobile telephone base stations, with radiating components based on fractal geometry. This technology significantly reduces the overall size of the antenna, allowing it to be incorporated under a single cylindrical radome, equivalent to 12 single-band panels in a traditional antenna.

This innovative line of TELNET Compact Antennas has significantly reduced visual impact. It can be assimilated almost imperceptibly into the urban environment by mimicking building elements. In addition, the small height and weight of this family of antennas simplifies installation and maintenance tasks.

MAST + ANTENNA SOLUTION

Each Compact Antenna can be supplied in monosector, bisector or trisector configurations. In addition, each antenna can be supplied in different colours and covers. This family of antennas is ready for RET (Remote Electrical Tilt) technology.

TELNET Compact Antennas are supplied with a modular mast. The masts can reach heights of up to 6 metres and have available a module to house the TMA inside. They are available in different colours and finishes, and three safety options to make installation safer.

Finally, the whole antenna and mast unit is supported by an anchoring mechanism. There are three types available, depending on the needs of each location: floating bedplate, ground pillar mounted and wall mounted.

Family TNA580 - Technical Features

Radio-Electrical	x2 Broadband Down			x2 Broadband Up		
Frequency Range	1710 - 2170 MHz			1710 - 2170 MHz		
	DCS // UMTS			DCS // UMTS		
Polarization	Xpol, +/- 45°			Xpol, +/- 45°		
Gain Max	17,3 dBi			17 dBi		
Gain +/- Avg. Dev	16,64 ± 0,2 dBi // 16,64 ± 0,3 dBi			16,64 ± 0,2 dBi // 16,64 ± 0,3 dBi		
Horizontal Beam width	63° // 61°			63° // 61°		
Vertical Beam width	7° // 6,5°			7° // 6,5°		
Cross Polar Discrimination						
Boresight	>25dB			>25dB		
Sector ±60°	>10dB			>10dB		
F/B Ratio Copolar (180°+/-30° cone)	27 dB			27 dB		
Side lobe suppression for first side lobe above horizon	15	17	15 dB	15	17	15 dB
	4°	10°	14°	4°	10°	14°
Electrical tilt continuously adjustable	4° - 14° (sector and band independent)			4° - 14° (sector and band independent)		
VSWR	< 1.5:1			< 1.5:1		
Interport Isolation	> 30 dB			> 30 dB		
Nullfill	25 dB			25 dB		
Impedance	50 Ohms			50 Ohms		
Max. Power per input	300W			300W		
Inter modulation Products (2*20W)	150dBc			150dBc		
Azimuth	+/-50° : Full Antenna Azimuth (as a block) +/-5°: Independent Azimuth per sector					
Prepared for RET	OK			OK		

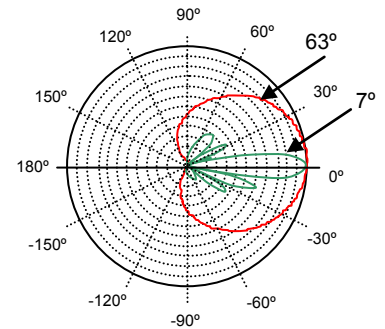

DCS pattern per sector

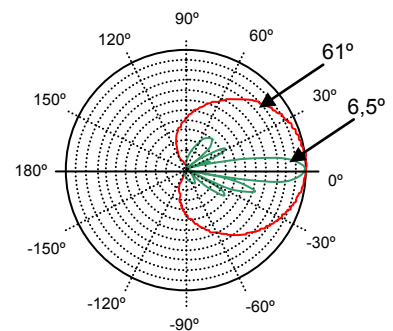

UMTS pattern per sector

Mechanical	
Input	24 x 7/16 female
Connectors position	Bottom, 3 x 8 (7/16)
Dimensions	Diameter: 450 mm Length: 2700mm + 300 mm
Weight	85 Kg.
Max. speed wind	200 Km/h

Material	
Radome	Fiber glass + polyester
End Caps	Stainless Steel
Screws and Nuts	Stainless Steel

Enviromental and mechanical tests	
IEC 60068-2-2: Dry Heat	IEC 60068-2-64: Random Vibration
IEC 60068-2-56: Damp Heat Steady State	IEC 60068-2-6: Sine Vibration
IEC 60068-2-30: Damp Heat Cyclic	IEC 60068-2-27: Shock Test
IEC 60068-2-14: Change of Temperature	IEC 60068-2-32: Free Fall Test
IEC 60068-2-1: Cold	IEC 60068-2-29: Bump Test
IEC 60068-2-18: Water (Handheld shower)	IEC 60068-2-52: Salt mist Cyclic
IEC 60068-2-11: Salt mist	

Telnet antennas have passed environmental tests recommended in ETS 300 019-2-4, and extensive test recommended by the main operators over the world.

Contact Information

Headquarters

Polígono Industrial Centrovía
c/ Buenos Aires, 18
50196 La Muela, Zaragoza
Spain

Tel.: (+34) 976 14 18 00
Fax: (+34) 976 14 18 10
comercial@telnet-ri.es

Commercial office in Madrid

Avda. Menéndez Pelayo, 85 - 1º A
28007 Madrid
Spain

Tel.: (+34) 91 434 39 92
Fax: (+34) 91 434 40 84

Commercial office in Lisbon

Avenida da Liberdade, 110
1269- 046 Lisbon
Portugal